

# **THE REGENERATIVE BRAKING SYSTEM, ELECTRIC MOTOR, AND GENERATOR FABRICATION**

Bhaskar.B.Katti, Poornima.K, Sridhar Gowda

Asst. Prof, Asst. Prof, Asst. Prof

[bbkatti@pdit.ac.in](mailto:bbkatti@pdit.ac.in), [mechpoornima@gmail.com](mailto:mechpoornima@gmail.com), [sridharmpheroor@gmail.com](mailto:sridharmpheroor@gmail.com)

Department of Mechanical, Proudhadivaraya Institute of Technology, Abheraj Baldota Rd, Indiranagar, Hosapete, Karnataka-583225

## **Abstract:**

The term "regenerative braking" refers to a mechanism that briefly stores the vehicle's kinetic energy as it slows down and then releases it again. One way to cut down on fossil fuel use is by using regenerative braking. A lot of power is dissipated as heat when you brake. The idea behind a regenerative braking system is to put this energy to good use rather than letting it go to waste. To compensate for kinetic energy lost while braking, an electric traction motor harnesses the vehicle's forward motion. In contrast, dynamic brakes and the traditional braking system both result in the undesirable conversion of surplus kinetic energy to heat and their associated waste. Electric motors are used as generators in the majority of regenerative braking systems to recover the energy.

**Keywords:** hp motor, dynamo, pulley.

## **1.INTRODUCTION**

Brakes are employed to stop or retard the motion of any moving body. In an automobile, brakes are equally important as the engine. In a conventional braking system, the motion is retarded or stopped by absorbing kinetic energy by friction; by making the contact of the moving body with a frictional rubber pad which causes the absorption of kinetic energy. This energy dissipates as heat into surroundings. Each time brakes are applied, the momentum gets absorbed to re-accelerate, the vehicle has to start from scratch, redeveloping it using power from the engine. Thus, it will ultimately result in the wastage of energy. A regenerative brake is an energy recovery mechanism that slows a vehicle by converting its kinetic energy into another form, which is used immediately or stored until needed. Thus, the generated energy during the braking is sent back into the supply system whereas, in battery electric and hybrid electric vehicles, the energy is stored in a battery or bank of capacitors for later use. Energy can also be stored by compressing air or in a rotating flywheel. There are many existing applications of regenerative braking 1. Many metro trains across the globe, are equipped with regenerative braking which returns about 25% of the electrical energy to the power source. 2. The Škoda transportation is producing electric trams equipped with regenerative braking system; which are widely being used across Europe.

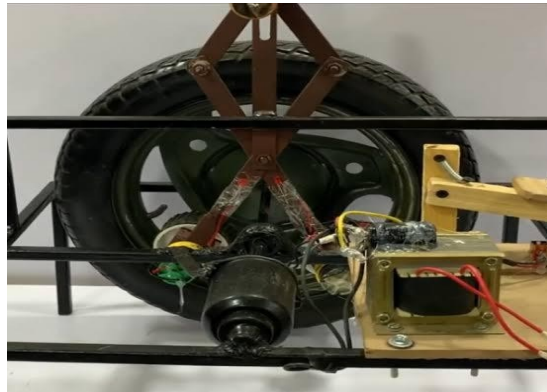

**Figure 1:- Regenerative Braking System**

## **2.OBJECTIVES**

**Energy recovery:** Regenerative braking systems are designed to recover energy that is normally lost during braking. When a vehicle brakes, kinetic energy is converted into heat and dissipated into the environment. A regenerative braking system captures some of this energy and converts it into electrical energy that can be stored in a battery or used to power electrical systems on the vehicle.

**Improved fuel efficiency:** By recovering energy that would normally be lost during braking, regenerative braking systems improves the fuel efficiency of a vehicle. This is because the recovered energy can be used to power the vehicle, reducing the amount of energy that needs to be supplied by the engine.

**Reduced emissions:** Because regenerative braking systems improve fuel efficiency, it also helps reduce emissions from vehicles. This is particularly important in the context of electric vehicles, which produce no tailpipe emissions, but may still rely on energy generated by power plants that produce emissions.

## **3.LITERATURE REVIEW**

Sayed Nashit, Sufiyan Adhikari, Shaikh Farhan, Srivastava Avinash and Amruta Gambhire, ‘Design, Fabrication and Testing of Regenerative Braking Test Rig for BLDC Motor’, 2016, 1881-84. In this paper (1) a test bench for testing of regenerative braking capability of a Brushless DC Motor is design and then fabricated. The project creates awareness to engineers towards energy efficiency and energy conservation. It concludes that the regenerative braking systems are more efficient at higher speed and it cannot be used as the only brakes in a vehicle. The definite use of this technology described as in the project in the future automobiles can help us to a certain level to sustainable and bright future of energy efficient world as a part of power that is lost can be regained by using the regenerative braking system.

Tushar L. Patil, Rohit S. Yadav, Abhishek D. are, Mahesh Saggam, Ankul Pratap, ‘Performance Improvement of Regenerative braking system’, International Journal of Scientific & Engineering Research Volume 9, Issue 5, (2018). 2229-5518. In this paper (2) the techniques to increase the efficiency of the regenerative braking system is mentioned. The technique mentioned was to reduce the weight of the automobile which increase performance, using super capacitor also improves the conversion rate of energy in regenerative braking system, making the automobile compact also tends to increase the efficiency of the system.

C. Jagadeesh Vikram, D. Mohan Kumar, Dr. P. Naveen Chandra, ‘Fabrication of Regenerative Braking System’, International Journal of Pure and Applied Mathematics Volume 119, (2018). 9973-9982. In this paper (3) the Fabrication process on the Regenerative Braking System had been implemented as per the prescribed measures has been taken and the future enhancements should be processed on basis of

the need of the study. The Implementation of the regenerative braking system be quite essential in automotive transportation with maximized performance in braking.

#### **4. MATERIALS & METHODOLOGY**

Regenerative braking system is used in vehicles to convert the kinetic energy generated during braking into electrical energy, which can then be used to recharge batteries or power other electrical systems in the vehicle. The materials and methodology used in this system typically involve the following components:

**Electric motor/generator:** A key component of the regenerative braking system is an electric motor/generator that is able to convert the kinetic energy generated during braking into electrical energy. This motor/generator is typically made of materials such as copper, steel, and various alloys. The electrical energy generated during braking is stored in a battery, which is typically made of materials such as lithium-ion, nickel-metal hydride, or lead-acid.

**Power electronics:** The electrical energy generated by the motor/generator is converted and controlled by power electronics, which typically include materials such as silicon, gallium arsenide, and various other semiconductors. The regenerative braking system works in conjunction with the conventional hydraulic or mechanical braking system of the vehicle. When the driver applies the brakes, the regenerative braking system will capture the kinetic energy generated during braking, and the conventional braking system provides additional stopping power as needed. The methodology for implementing a regenerative braking system typically involves designing and integrating the various components mentioned above into the vehicle's existing electrical and mechanical systems. This can involve a variety of engineering and design considerations, such as optimizing the efficiency of the motor/generator, selecting the appropriate battery chemistry and capacity, and designing the power electronics to provide optimal control and performance. Overall, regenerative braking systems represent an important technology for increasing the energy efficiency of vehicles and reducing their carbon footprint, and continue to be an active area of research and development in the automotive industry.

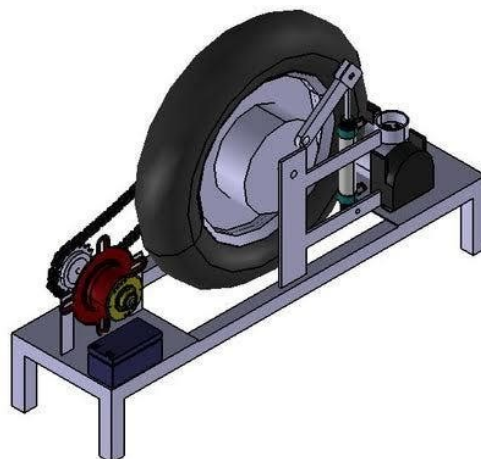

**Figure 2. Schematic view of Regenerative Braking System**

#### **5. CONSTRUCTION AND WORKING MECHANISM**

##### **5.1. Construction:**

The motor or generator is typically integrated into the vehicle's drivetrain, and is used to convert the vehicle's kinetic energy into electrical energy during braking.

The energy is then stored in a battery or other energy storage device, which can be used to power the vehicle's electrical systems or assist the vehicle's acceleration. The power electronics module is used to control the flow of energy between the motor or generator and the battery, and to convert the electrical energy into a form that can be stored in the battery. The braking control system is used to determine when the vehicle is braking, and to control the regenerative braking system to capture and store energy.

### 5.2. Working mechanism:

When the driver applies the brakes, the braking control system detects the deceleration and signals the power electronics module to activate the motor or generator. The motor or generator then converts the kinetic energy of the vehicle into electrical energy, which is stored in the battery. The power electronics module controls the flow of energy between the motor or generator and the battery to ensure that the battery is charged efficiently and safely. Once the vehicle comes to a stop, the regenerative braking system has captured as much energy as possible, and the energy can be used to power the vehicle's electrical systems or assist in acceleration. In some cases, the regenerative braking system can also be used to slow the vehicle down gradually without engaging the traditional friction brakes, which can further extend the life of the brake pads.

Overall, regenerative braking systems are an important technology for improving the efficiency and sustainability of transportation, and they are increasingly being used in a wide range of vehicles, from electric cars to hybrid buses and trains.

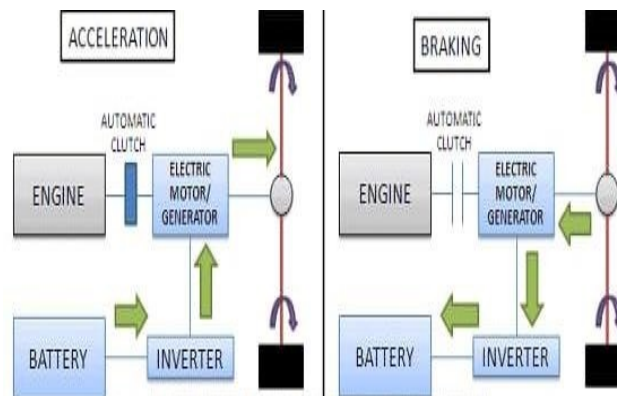

**Figure- 3. Schematic of Regenerative Braking System.**

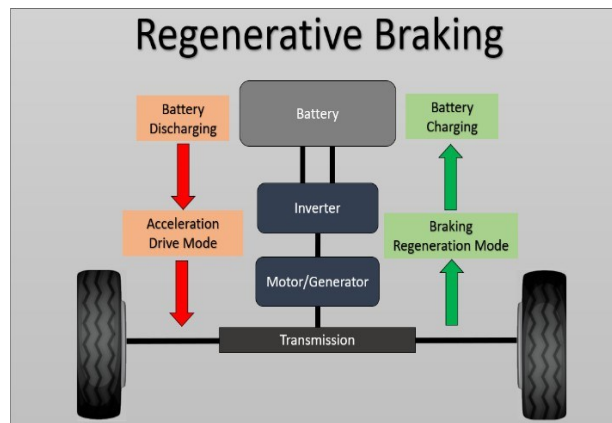

## 6. COMPONENTS

- SQUARE TUBE
- ¼ HP MOTOR
- ON/OFF SWITCH
- WHEELS
- BELT DRIVE
- PULLEY
- DYNAMO
- 12V BATTERY

### 6.1 SQUARE TUBE



A square tube mild steel is a type of low-carbon steel that is often used for structural applications because it is affordable, easy to work with, and has good strength and ductility. Square tubes made from mild steel are commonly used in construction, manufacturing, and other industries for a variety of purposes such as supports, frames, and machinery components.

### 6.2 ¼ HP MOTOR



An electric HP motor is an electrical machine that converts electrical energy into mechanical energy. Most electric motors operate through the interaction between the motor's magnetic field and electric current in a wire winding to generate force in the form of torque applied on the motor's shaft.

A 1/4 horsepower motor typically contains a rotor, stator, bearings, and a housing. The rotor is the rotating part of the motor and is usually made of a cylindrical iron core with copper wire windings around it. The stator is the stationary part of the motor and typically consists of a laminated iron core with copper wire windings. The stator is mounted inside the motor housing and surrounds the rotor.



The bearings are used to support the rotor and allow it to rotate smoothly. They are typically made of steel or ceramic and are lubricated to reduce friction and wear. The motor housing is the outer casing that encloses the rotor, stator, and bearings. It is usually made of aluminium, steel, or plastic.

### 6.3 ON/OFF SWITCH



In electrical engineering, a switch is an electrical component that can disconnect or connect the conducting path in an electrical circuit, interrupting the electric current or diverting it from one conductor to another. The most common type of switch is an electromechanical device consisting of one or more sets of movable electrical contacts connected to external circuits.

An on/off switch, also known as a power switch or toggle switch, is a simple electrical component that is used to turn a device or appliance on or off. Its purpose is to interrupt or complete an electrical circuit, controlling the flow of electricity to the device.

When the switch is turned on, it connects the two ends of the circuit and allows electricity to flow through, powering the device. Conversely, when the switch is turned off, it breaks the circuit, stopping the flow of electricity and turning the device off.

### 6.4 WHEEL



A wheel is a circular component that is used to rotate on an axle bearing. The wheel is one of the key components of the wheel and axle, which is one of the six simple machines. Wheels, in conjunction with axles, allow heavy objects to be moved easily, facilitating movement or transportation while supporting a load, or performing labor in machines. Wheels are also used for other purposes, such as a ship's wheel, steering wheel, potter's wheel, and flywheel.

## 6.5 BELT DRIVE



V-belts are more commonly used in traditional mechanical systems, where they provide a cost-effective and reliable means of transmitting power between rotating components. However, as electric and hybrid vehicles become more prevalent, new and innovative braking systems are being developed to improve energy efficiency and reduce environmental impact.

## 6.6 PULLEY



In a pulley system, a rope or a belt is looped around the pulley wheels. When a force is applied to one end of the rope, it causes the pulley to rotate, which in turn, causes the object attached to the other end of the rope to move.

## 6.7 DYNAMO



A dynamo motor is a type of electric generator that converts mechanical energy into electrical energy. It works on the principle of electromagnetic induction, which was discovered by Michael Faraday in the early 19th century. The basic components of a dynamo motor include a rotating armature or coil, a stationary magnetic field, and a set of brushes that make contact with the armature to collect the generated electrical current. When the armature is rotated within the magnetic field, an electromotive force (EMF) is induced in the armature coil, which produces a current flow. The brushes are used to collect the current and transfer it to an external circuit.

### 6.8. 12V BATTERY



© Nil Group photo

Lead-acid batteries are commonly used in a variety of applications due to their low cost, durability, and ability to deliver high currents. They are often used in automotive applications to start engines and provide power for accessories, such as lights and radios. They are also used in backup power systems, such as those found in data centers, hospitals, and telecommunications facilities. A 12-volt lead-acid battery typically consists of six cells, each providing 2 volts.

$$V = \frac{2 \pi N}{60} r_w \times \frac{18}{5} \quad V_1 = \frac{2 \pi \times 150}{60} \times 0.28 \times \frac{18}{5}$$

### 7.0 FABRICATION IMAGE



### 8.0 CALCULATIONS:

**Table: 1. Experimental readings**

S.NO	RPM before brake pedal pressed	RPM after brake pedal pressed	Voltage output
1	150	141	9.34
2	175	159	11.88
3	200	178	12.81
4	225	196	13.91
5	250	224	14.49
6	300	281	14.49
7	400	382	14.49



The wheel radius is considered to be  $r_w = 0.280\text{m}$ . Hence, vehicles expected speed for 150rpm motor speed will be,

Vehicle speed,

$$V_1 = 15.83 \text{ km/hr.}$$

**Table:2 .Modified experimental results**

S.NO	Expected vehicle speed(kmph)	Voltage output
1	15.83	9.34
2	18.47	11.88
3	21.11	12.81
4	23.22	13.91
5	26.38	14.49
6	31.66	14.49
7	42.22	14.49

### 9.0 GRAPH'S

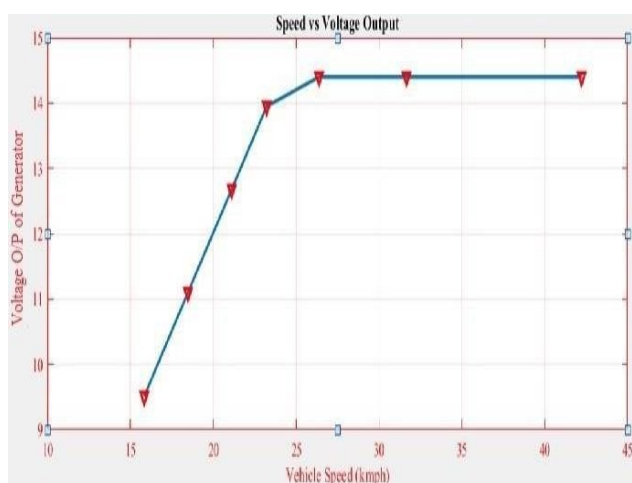

(a) Speed  $V_s$  voltage output

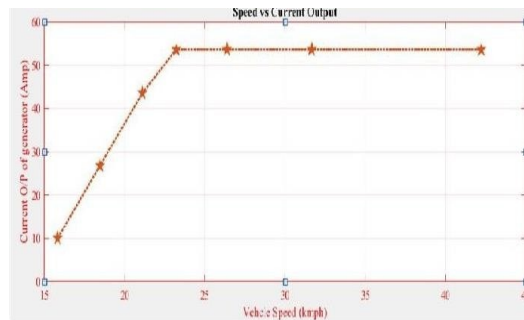

(b) speed  $V_s$  current output

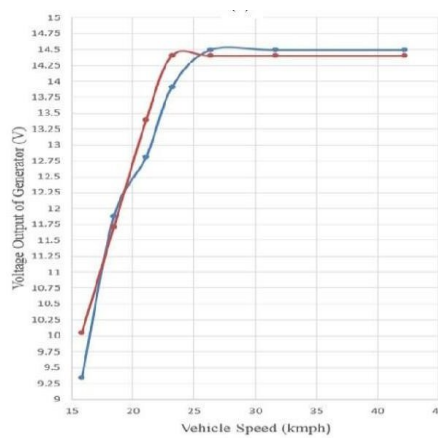

(c) speed  $V_s$  voltage output

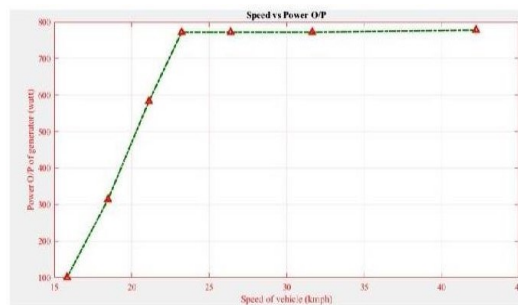

(d) speed  $V_s$  power output

## 8.FUTURE SCOPE

The feature and scope of a regenerative braking system can vary depending on the type of vehicle, the design of the braking system, and the intended use of the system. Here are some of the key features and scope of a typical regenerative braking system:

**Energy recovery:** Regenerative braking system are designed to recover energy which normally be lost during braking. This energy used to power various vehicle systems or stored in a battery for later use.

**Efficiency:** Regenerative braking system can improve the overall efficiency of a vehicle by reducing the amount of energy needed to operate the vehicle. This can result in improved fuel economy and reduced emissions.

**Braking performance:** Regenerative braking system can also improve the overall braking performance of a vehicle by providing additional braking force and reducing the wear and tear on traditional braking components.

**System integration:** Regenerative braking system can be integrated with other vehicle systems, such as the engine and transmission, to optimize overall vehicle performance.

**Maintenance:** Regenerative braking system require regular maintenance to ensure that they are functioning properly and to prevent damage to other vehicle components.

Overall, regenerative braking systems can provide significant benefits to vehicle performance and efficiency, and they are becoming increasingly common in hybrid and electric vehicles.

## REFERENCES

1. Cody J, 2008, "Regenerative Braking Control for a BLDC Motor in Electric Vehicle Applications", Honors Paper in Bachelor of Engineering degree, University of South Australia, School of Electrical and Information Engineering.
2. Ford R. 2007, "Regenerative Braking Boosts Green Credentials, Railway gazette", [http://www.railwaygazette.com/features/view/article/2007/07/7577/regenerative\\_braking\\_boosts\\_green\\_credentials.htm](http://www.railwaygazette.com/features/view/article/2007/07/7577/regenerative_braking_boosts_green_credentials.htm), viewed: 23rd June 2008.
3. "Regen Braking" Q4D Sales Information Web Page, <http://www.4qd.co.uk/fea/regen.html>, viewed: 15th Aug 2008.
4. Brown W., "AN857 Brushless DC Motor Control Made Easy." Microchip Technology Inc, available from [http://www.microchip.com/stellent/idcplg?IdcService=SS\\_GET\\_PAGE&nodeId=1824&appName=en012037](http://www.microchip.com/stellent/idcplg?IdcService=SS_GET_PAGE&nodeId=1824&appName=en012037), viewed: 15 August 2008.
5. Rashid M. H., 2004, "Power Electronics: Circuits, Devices and Applications" Prentice Hall, 3rd Edition
6. Emadi, A., 2005, "Handbook of Automotive Power Electronics and Motor Drives", CRC Taylor & Francis
6. Ramamoorthy, R., Kanagasabai, V., Kausalya, R., Impact of celebrities' image on brand, International Journal of Pure and Applied Mathematics, V-116, I-18 Special Issue, PP-251-253, 2017
7. Ramamoorthy, R., Kanagasabai, V., Vignesh, M., Quality assurance in operation theatre withreference to fortis malar hospital, International Journal of Pure and Applied Mathematics, V-116, I-14 Special Issue, PP-87-93, 2017
8. Ramya, N., Arthy, J., Honey comb graphs and its energy, International Journal of Pure and Applied Mathematics, V-116, I-18 Special Issue, PP-83-86, 2017
9. Ramya, N., Jagadeeswari, P., Proper coloring of regular graphs, International Journal of Pure and Applied Mathematics, V-116, I-16 Special Issue, PP-531-533, 2017
10. Ramya, N., Karunagaran, K., Proper, star and acyclic coloring of some graphs, International Journal of Pure and Applied Mathematics, V-116, I-16 Special Issue, PP-43-44, 2017